



**SEE ALSO
USER'S GUIDE**

MIL-STD-1553 advanced integrated MUX (AIM) hybrid

DESCRIPTION

DDC's BUS-61553 Advanced Integrated Mux (AIM) Hybrid is a complete MIL-STD-1553 Bus Controller (BC), Remote Terminal Unit (RTU), and Bus Monitor (MT) device. Packaged in a single 78-pin DIP package, the BUS-61553 contains dual low-power transceivers, complete BC/RT/MT protocol logic, a MIL-STD-1553-to-host interface unit and 8K x 16 RAM.

Using an industry standard dual transceiver and standard status and control signals, the BUS-61553 simplifies system integration at both the MIL-STD-1553 and host processor interface levels.

All 1553 operations are controlled through the CPU access to the

shared 8K x 16 RAM. To ensure maximum design flexibility, memory control lines are provided for attaching external RAM to the BUS-61553 address and data buses and for disabling internal memory; the total combined memory space can be expanded to 64K x 16. All 1553 transfers are entirely memory-mapped; thus the CPU interface requires minimal hardware and/or software support.

The BUS-61553 operates over the full military -55°C to +125°C temperature range. Available screened to MIL-PRF-38534, the BUS-61553 is ideal for demanding military and industrial microprocessor-to-1553 interface applications.

FEATURES

- **Fully Intergrated Terminal Including:**
 - Dual Transceiver
 - BC/RT/MT Protocol
 - Memory Management Unit
 - Processor Interface Logic
 - 8K x 16 RAM
- **CMOS and Bipolar Technologies**
- **Internal Interrupt Status and Time Tag Registers**
- **High Reliability**
- **883B Processing Available**

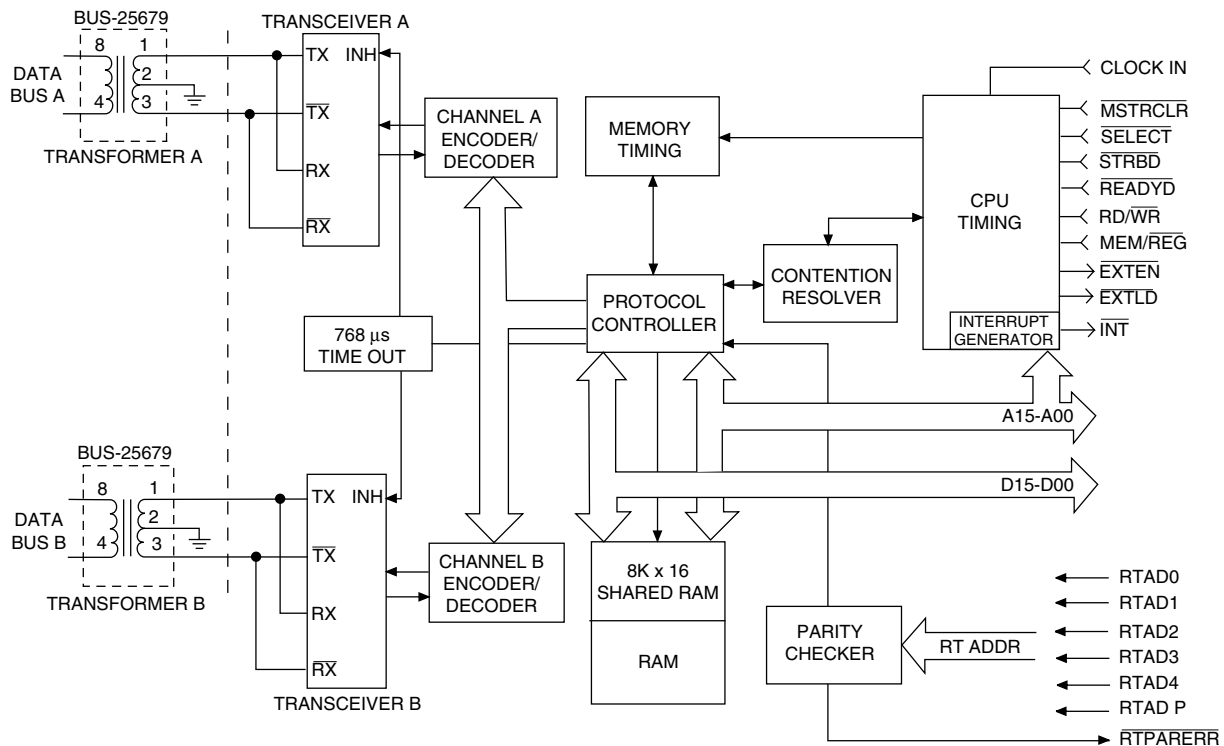

FIGURE 1. BU-61553 BLOCK DIAGRAM

ORDERING INFORMATION

BUS-615XX-XX0X

- Supplemental Process Requirements:**
 - S = Pre-Cap Source Inspection
 - L = Pull Test
 - Q = Pull Test and Pre-Cap Inspection
 - K = One Lot Date Code
 - W = One Lot Date Code and PreCap Source
 - Y = One Lot Date Code and 100% Pull Test
 - Z = One Lot Date Code, PreCap Source and 100% Pull Test
 - Blank = None of the Above
- Process Requirements:**
 - 0 = Standard DDC Processing, no Burn-In (See Page 13.)
 - 1 = MIL-PRF-38534 Compliant
 - 2 = B*
 - 3 = MIL-PRF-38534 Compliant with PIND Testing
 - 4 = MIL-PRF-38534 Compliant with Solder Dip
 - 5 = MIL-PRF-38534 Compliant with PIND Testing and Solder Dip
 - 6 = B* with PIND Testing
 - 7 = B* with Solder Dip
 - 8 = B* with PIND Testing and Solder Dip
 - 9 = Standard DDC Processing with Solder Dip, no Burn-In (See Page 13.)
- Temperature Grade/Data Requirements:**
 - 1 = -55°C to +125°C
 - 2 = -40°C to +85°C
 - 3 = 0°C to +70°C
 - 4 = -55°C to +125°C with Variables Test Data
 - 5 = -40°C to +85°C with Variables Test Data
 - 8 = 0°C to +70°C with Variables Test Data
- Power Supply**
 - 3 = -15 V Transceivers
 - 4 = -12 V Transceivers
 - 5 = +5 V Transceivers—Call Factory
 - 6 = Transceivers—Use with BUS-63102II—Call Factory
- Packaging**
 - 5 = DDIP
 - 6 = Flat Pack

These products contain tin-lead solder finish as applicable to solder dip requirements.

STANDARD DDC PROCESSING FOR HYBRID AND MONOLITHIC HERMETIC PRODUCTS		
TEST	MIL-STD-883	
	METHOD(S)	CONDITION(S)
INSPECTION	2009, 2010, 2017, and 2032	—
SEAL	1014	A and C
TEMPERATURE CYCLE	1010	C
CONSTANT ACCELERATION	2001	3000g
BURN-IN	1015 ^(Note 1) 1030 ^(Note 2)	TABLE 1

Notes:
 1. For Process Requirement "B*" (refer to ordering information), devices may be non-compliant with MIL-STD-883, Test Method 1015, Paragraph 3.2. Contact factory for details.
 2. When applicable.

NOTES

The information in this data sheet is believed to be accurate; however, no responsibility is assumed by Data Device Corporation for its use, and no license or rights are granted by implication or otherwise in connection therewith.
Specifications are subject to change without notice.

Please visit our web site at www.ddc-web.com for the latest information.



105 Wilbur Place, Bohemia, New York 11716-2426

For Technical Support - 1-800-DDC-5757 ext. 7771

Headquarters - Tel: (631) 567-5600 ext. 7257 or 7381, Fax: (631) 567-7358

Europe - Tel: +44-(0)1635-811140, Fax: +44-(0)1635-32264

Asia/Pacific - Tel: +81-(0)3-3814-7688, Fax: +81-(0)3-3814-7689

World Wide Web - <http://www.ddc-web.com>



DATA DEVICE CORPORATION
REGISTERED TO ISO 9001:2000
FILE NO. A5976
PRINTED IN THE U.S.A.