

USB Avionics Device with MIL-STD-1553 and ARINC 429 Interfaces

Data Sheet

MODEL: BU-67102/3U



ACEXTREME™



Features

- Portable USB 2.0 Device
- 1 or 2 Dual Redundant MIL-STD-1553 Channels
 - BC/Monitor or Multi-RT/Monitor per MIL-STD-1553 Channel
- 4 ARINC 429 Receive Channels
- 2 ARINC 429 Transmit Channels
- 8 User-Programmable Digital Discrete I/O's
- IRIG-B Time Code Input
- 1 Pulse per Second Output
- 1 MB RAM with Parity per 1553 Channel
- 48-bit / 100ns Time Stamp
- Extended Temperature Hardware Available
- IRIG-106 Chapter 10 Monitor
- Multiple Configuration Options:
 - ARINC 429 & MIL-STD-1553
 - MIL-STD-1553 Only
 - ARINC 429 Only
- Included Software:
 - High-Level C Software Development Kits (SDK) and Drivers
 - Common Test/Embedded API
- Optional Software:
 - BusTrACEr™ MIL-STD-1553 Graphical Monitor/Generator
 - *dataMARS* Real-Time Avionics Bus Analyzer
 - ARINC 429 Data Bus Analyzer
 - ARINC 615 Data Loader
 - 1553/429 LabVIEW® Package

DESCRIPTION

The BU-67102/3U USB device provides a portable off-the-shelf interface to 1 or 2 dual-redundant MIL-STD-1553 channels, 4 ARINC 429 Receive channels, 2 ARINC 429 Transmit channels, 8 user-programmable digital discrete I/O's, IRIG-B time code input, and 1 Pulse-per-Second (PPS) Output. The device is available as 1553 only, 429 only, or fully populated with 1553/429 Multi-I/O. The USB device can be powered directly from the USB interface or by an external power source (included).

Each 1553 channel can operate in Bus Controller (BC) or Multi-RT (0 to 31) modes, and each mode has the ability to run a concurrent Bus Monitor (MT). The ARINC 429 channels can support full data line rate for low, high, and ARINC 575 speed communications with automatic slew rate adjustment while providing multiple reception and transmission methods for ARINC messages.

The device includes the BU-69092S MIL-STD-1553 AceXtreme C Software Development Kit (SDK) and the DD-42992S ARINC 429 C SDK, including source code samples and detailed documentation, to support all modes of operation. Optional graphical software packages include the MIL-STD-1553 BusTrACEr Analyzer/Simulator, ARINC 429 Data Bus Analyzer (DBA), ARINC 615 Data Loader, LabVIEW Multi-I/O support package, and *dataMARS* Data Analysis Tool. The optional software packages allow users to easily generate or monitor avionic data for 1553 or 429 operation.

APPLICATIONS

The 1553/429 USB device is suited for a wide variety of applications including, but not limited to, box level testing, simulation, portable test equipment, flight line test and diagnostic, software development, system integration, and debugging. The device enhances the work of developers, integrators, testers, field personnel and flight test crew through advanced 1553 and 429 capabilities that are accessible in a portable form factor. The USB interface makes it ideal for use with desktop, laptop, or tablet computers.

Make Sure the next Card you purchase has...



MIL-STD-1553 CHANNELS

Each 1553 channel can emulate a Bus Controller (BC), multiple Remote Terminals (RTs), a Bus Monitor (MT), BC/MT, or Multi-RT/MT modes independently per 1553 channel. Standard features include 1 MB of RAM per 1553 channel, 48-bit message time tagging with a programmable resolution down to 100ns, IRIG-B time code input, 1 PPS output, transformer and direct coupling, triggers, extensive BC & RT frame structures, error detection, RT Status Bit and Mode Code responses, along with advanced BC functionality.

The advanced BC architecture provides a high degree of flexibility and autonomy by providing Major and Minor frame schedule control, streaming data interface, asynchronous message insertion, bulk data transfers, double buffering, message retry, bus switching strategies, data logging, and fault reporting.

The RT architecture provides flexibility in meeting all common MIL-STD-1553 protocols (1553A/B, 1760) while emulating up to 31 RT addresses on one 1553 channel. The choices of Multi-RT buffering and interrupt options provide robust support for synchronous and asynchronous messaging, while ensuring data sample consistency and supporting bulk data transfers.

The device includes a message monitor mode and a combined Multi-RT/MT mode where the MT will monitor all 1553 communications on the bus, including the 1553 channel's assigned RT addresses. The Bus Monitor mode provides complete error detection on 100% fully loaded buses, while providing features for advanced error detection to isolate faults at a particular word within a 1553 message.

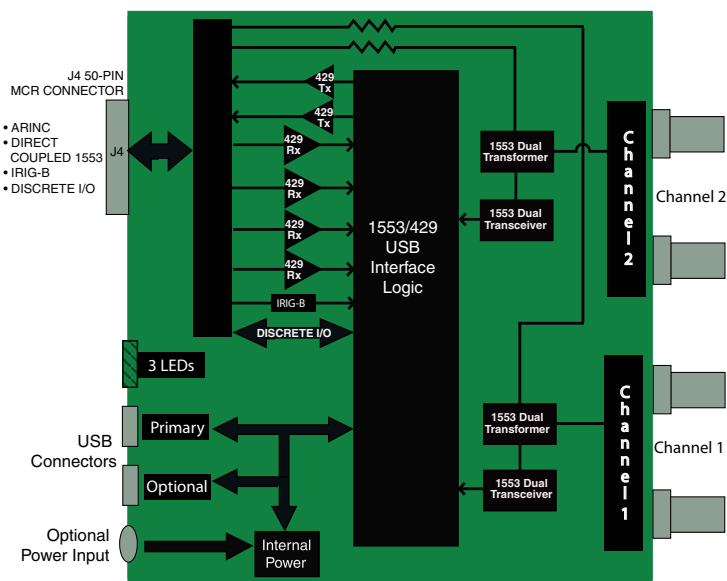

FIGURE 1. BU-67103U BLOCK DIAGRAM

DATA STREAMING ENGINE

The Data Streaming Engine, used in all modes, transfers all data between the host and the 1553 device. By using modern burst transfer technologies (DMA), CPU utilization and latency are drastically decreased when compared to older 1553 designs.

DIGITAL DISCRETE I/O'S

Eight Digital Discrete I/O's pins are individually programmable to be either an output with wraparound or input-only digital discrete. Digital discrete inputs are +5V tolerant, and the outputs are +3.3V.

IRIG-B TIME CODE SUPPORT

The device includes an analog IRIG-B input and digital IRIG-B input. IRIG-B time codes can be accessed in a convenient time data packet format.

PULSE-PER-SECOND OUTPUT

This output provides a 1 Pulse-per-Second (PPS) signal, synchronized to the SYNC signal of the IRIG-B time code.

ARINC 429 CHANNELS

Each ARINC 429 channel can support full data line rate for low and high speed communications with automatic slew rate adjustment while providing multiple reception and transmission methods for ARINC 429 data. A software programmable option allows the user to program the device to receive ARINC 575 data.

Each ARINC 429 channel provides message scheduling, label filtering, and full error detection. Received data can be stored in either FIFO buffers or system address label mailboxes. The ARINC 429 channels feature independent selection of data rate, parity choices for odd, even, or no parity checking, and automatic transmit channel slew rate adjustment. Transmitted data can be sent in FIFO mode or scheduled rate mode on each transmit channel. The device also provides the advanced capability to concurrently mix transmit FIFO mode messages with scheduled rate mode messages on the same channel.

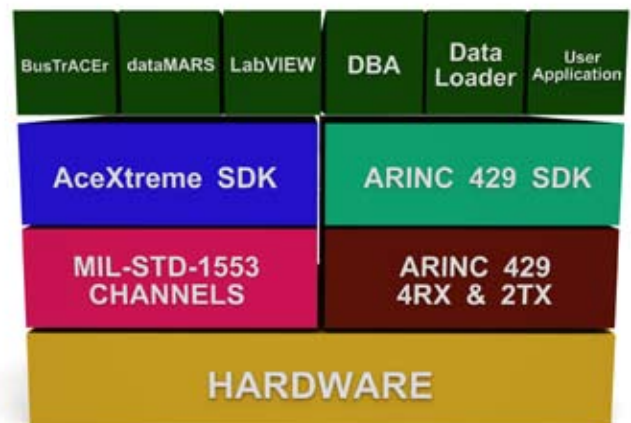

FIGURE 2. 1553 & 429 SOFTWARE/HARDWARE ARCHITECTURE

MIL-STD-1553 and ARINC 429

- USB 2.0 Interface Powered from USB
- 6V auxiliary power supply included
- 48-bit time tag, 100 ns programmable resolution
- IRIG-B Time Code Input (Digital/Analog)
- 1 Pulse per Second Output
- 8 User-Programmable Digital Discrete I/O
- DMA Engine for Low CPU Utilization for all 1553 modes

MIL-STD-1553

- Up to 2 Dual Redundant MIL-STD-1553 Channels
- Transformer and Direct Coupled 1553 I/O
- 1 MB RAM with Parity per 1553 Channel
- MIL-STD-1553A Support
- High Level C Software Development Kit
- BC, Multi-RT, MT, BC/MT, Multi-RT/MT Operating Modes

1553 Bus Controller

- Multiple Methods of Message Scheduling
 - Major and Minor frames
 - High and Low Priority Asynchronous Messages
 - On Demand Streaming Interface
- Modify Messages or Data while BC is running
- Conditional Messages or Subroutines based on User Defined Conditions
- Multiple BC retry programmable options
- Detects and Reports 1553 Errors
- Fully User-Definable Interrupts
 - Message and/or Frame completion
 - Message error
 - User Defined (Custom)
- Optional Concurrent Bus Monitor
- Flexible support for data streaming or bulk data transfer

1553 Remote Terminal

- Emulate up to 31 addresses simultaneously
- Software-Programmable RT Addresses
- Choice of Buffering per Sub-address
 - Single Message
 - Double Buffering
 - Circular Buffering
- Programmable Interrupt Conditions
 - Buffer servicing required
 - Illegal command received
 - Selective Message Complete
- Stack with Descriptors for Individual Messages
- Message Status, Time Tag, Command Word, Data Words
- Programmable Command Illegalization based on:
 - RT address
 - Transmit/Receive
 - RT Sub-Address
 - Word Count/Mode Code
- Programmable Busy by Sub-address
- Optional Concurrent Bus Monitor

1553 Bus Monitor

- Selective Message Monitor
- Filter Based on RT Address, T/R bit, Sub-address
- Message Status, Time Tag, Command Word, Data Words
- Simultaneous RT/Message Monitor Option
- Simultaneous BC/Message Monitor Option
- Advanced Bus Error Detection to isolate bus failures
- Messages formatted as per IRIG-106 Chapter 10
- Programmable Interrupt Conditions
 - Buffer servicing required

MIL-STD-1553 Built-In Self-Test Capability

- RAM Self Test
- Register Self Test
- Online Loopback Test
- Capability to Test Transmitter Timeout Function

ARINC 429

- High / Low Speed Operation with automatic slew rate adjustment
- Four Receive Channels, Two Transmit Channels
- FIFO or Mailbox Reception Methods
- FIFO and/or Scheduled Transmission Methods
- Message Filtering
- Supports ARINC 429/571/575/582/603/615/709/710/711/712/740/741/744

Included Software

- Complete C SDKs for MIL-STD-1553 and ARINC 429
 - Plug-n-Play Windows 2000 and Windows XP Drivers
 - C SDK with high-level functions for all operating modes
 - Abstracts all low-level hardware memory/registers
 - Common Test/Embedded API for easy transition to other DDC hardware platforms.

Optional Software

- BusTrACEr 1553 Graphical Analyzer/Simulator
 - Provides an Easy-to-Use Graphical User Interface (GUI) for MIL-STD-1553
 - Simulates any operating mode (BC, Multi-RT, Monitor) of device
 - Provides 'C' Source Code Generation for custom stand-alone applications
- Commercial Avionics Utilities Suite
 - Provides a Graphical User Interface for ARINC 429 bus analysis and simulation
 - Provides advanced filtering, message scheduling, triggers, and Engineering Units Conversion
 - ARINC 615 Data Loader provides a software interface to upload/download data to airborne computers
- MIL-STD-1553 and ARINC 429 LabVIEW Support Package
 - High Level VIs to easily program the card
 - Detailed Sample Application VIs
 - Conforms to National Instrument's Driver Model
- dataMARS Real-Time Avionics Bus Analysis Tool
 - Locate Data Anomalies and Trends Using Real-Time Graphics
 - Store all or selected Real-Time Data of Multiple MIL-STD-1553 and Multiplex Channels
 - Trigger Storage based on Parameter Values, Timing, Bus Errors and Complex Expressions
 - Define a Complete User Database (ICD), with Message/Label and Parameter Definitions

Included Accessories

All USB device models include the following accessories:

- 1 USB Cable (PN 5810-0020-0001)
- 1 AC Power Adapter by CUI Inc, EMS060300-P5P-SZ (PN 5501-0159-0001)
- 1 50 Pin D-Connector (PN 5320-1009-0001)
- 1 50 Pin D-Connector Shell (PN 5508-0159-0001)

The BU-67102U Rugged USB device additionally comes with the following accessories:

- 5 Mounted-Head Cable ties (PN 5501-0169-0001)
- 1 Cable Tie Screw (PN 5465-1957-0015)
- 1 Cable Tie Washer (PN 5471-5795-0804)

ORDERING INFORMATION

BU-6710XUX00L-JL0

Test Criteria:

0 = none

Environmental Temperature Options:

JL = 0°C to +55°C Operating Temperature Range

CA = -40°C to +71°C Operating Temperature Range

Lead Free Options:

L = This product contains Tin Lead Solder

I/O Options:

OPTION #	CHANNEL NUMBER & TYPE			
	1553	ARINC 429 Rx	ARINC 429 Tx	Discrete I/O
0 =	-	4	2	8
1 =	1	-	-	8
2 =	2	4	2	8

Card Type:

02U = Rugged USB Device (only available with "CA" temp option -40°C to +71°C)

03U = Non-Rugged USB Device for Lab Use (only available with "JL" temp option 0°C to +55°C)

Family:

671 = Single-Function AceXtreme (BC, Multi-RT, MT, BC/MT, Multi-RT/MT)

INCLUDED SOFTWARE:



AceXtreme SDK

BU-69092SX - MIL-STD-1553 AceXtreme Software Development Kit (SDK)
Operating System:
0 = Windows 2000/XP

ARINC 429 SDK

DD-42992SX - ARINC 429 Multi I/O Software Development Kit (SDK)
Operating System:
0 = Windows 2000/XP

OPTIONAL SOFTWARE:



BU-69066S0-X - MIL-STD-1553 BusTrACER Graphical Analyzer/Simulator for Windows 2000/XP
1 = USB License Key



Commercial Avionics Utilities Suite

DD-42999S0-X - ARINC 429 Data Bus Analyzer & ARINC 615 Data Loader for Windows 2000/XP
1 = USB License Key



dataMARS Real-Time Avionics Bus Analysis Software

BU-694X4DM-64 V M dataMARS Data Analyzer

DM = dataMARS Data Monitoring, Analysis, & Retrieval System



MIL-STD-1553/ARINC 429 LabVIEW Support Package

BU-69093S0-X - MIL-STD-1553/ARINC 429 LabVIEW Support Package for Windows 2000/XP
1 = USB License Key



The information in this Data Sheet is believed to be accurate; however, no responsibility is assumed by Data Device Corporation for its use, and no license or rights are granted by implication or otherwise in connection therewith. Specifications are subject to change without notice.

Call DDC or visit www.ddc-web.com for a quote today:



105 Wilbur Place, Bohemia, New York, U.S.A. 11716-2426
For Technical Support - 1-800-DDC-5757 ext. 7771
Headquarters, N.Y., U.S.A. - Tel: (631) 567-5600, Fax: (631) 567-7358
United Kingdom - Tel: +44-(0)1635-811140, Fax: +44-(0)1635-32264

France - Tel: +33-(0)1-41-16-3424, Fax: +33-(0)1-41-16-3425
Germany - Tel: +49-(0)89-1500-12-11, Fax: +49(0)89-1500 12-22
Japan - Tel: +81-(0)3-3814-7688, Fax: +81-(0)3-3814-7689